

17/11/2023

No: 3597

Quotation

To:
Gail Springett
The Coddenham Centre
Mary Day Close
Coddenham, IP6 9SR

From:
Simon Mahony
Ebor Catering Systems
Unit 9
Buckley Road Industrial Estate
Rochdale
OL12 9EF
Mob 07831 549855
Office 01706 291666
VAT No 320 7887 93

Project:
Dishwasher

Job Reference Number:
3597

Dear Gail

Thank you for your enquiry with Ebor Catering Systems, please find attached our quotation for your consideration, all prices are subject to VAT at the standard rate and are valid for 30 days from date of quote. Title of goods remains with Ebor Catering Systems Ltd until paid for in full. All subject to our standard T&C's

Any items marked as optional or alternative are not included in the project total price

Item	Qty	Description	Sell	Sell Total
1	1 ea	DISHWASHER, UNDERCOUNTER Maidaid-Halcyon Amika Dishwasher, under counter, soft touch controls, drain pump breaktank, internal water softener, 90/150 sec. cycle, (1) 500 x 500mm open cup/glass rack & (1) 500 x 500mm pegged rack, 15 litre tank capacity, 10°C-50°C water supply, wash tank 60°C (adjustable), rinse boiler 82°C (adjustable), built-in rinse aid & detergent dispenser, stainless steel exterior & interior, height excludes adjustable feet which will add 10-20mm Dimensions 810(h) x 580(w) x 610(d)	£2,245.00	£2,245.00
	1 ea	1 year parts & labour warranty, standard		
			ITEM TOTAL:	£2,245.00
2	1 ea	DISHWASHER, UNDERCOUNTER	£1,974.00	<Alternate>



Maidaid-Halcyon

Amika Dishwasher, under counter, soft touch controls, drain pump, breaktank, 90/180sec. cycle, (1) 500 x 500mm open cup/glass rack & (1) 500 x 500mm pegged rack, 20 litre tank capacity, 10°C-50°C water supply, wash tank 60°C (adjustable), rinse boiler 82°C (adjustable), built-in rinse aid & detergent dispenser, stainless steel exterior & interior, height excludes adjustable feet which will add 10-20mm
 Dimensions 810(h) x 580(w) x 610(d)

- 1 ea 1 year parts & labour warranty, standard <Alternate>
- 1 ea 240v/50/1-ph, 6.5kW, 30.0 amps, standard <Alternate>

ITEM TOTAL: <Alternate> £1,974.00

3 1 ea **WORK TABLE** £329.00 £329.00
 Southcroft Engineering Co Ltd
 Stainless steel wall bench, upstand rear & right hand side
 Open under to accept 2 x undercounter dishwashers
 overall 1520 x 650 x 900mm high

ITEM TOTAL: £329.00

4 1 ea **DELIVERY** £133.00 £133.00
 Ebor Catering Systems Ltd
 Delivery of fabrication

ITEM TOTAL: £133.00

5 1 ea **INSTALLATION** £495.00 £495.00
 Apollo Trading Ltd
 Installation of dishwasher to include alterations to water & waste
 to accept new machine - New electric supply by customer

Installation of above equipment to services brought to within one metre by others, assuming clear & level ground floor site unhindered by other trades, all in normal working hours. All services to be complete and live at time of installation as price includes installation and commissioning in one continuous visit. Any additional visits due to services not being live or complete on installation will be chargeable. Price includes delivery and unpacking but EXCLUDES Earth bonding, disposal of packaging and removal of protective films.

All extract systems include installation but EXCLUDE builders, joiners, electricians works, provision of scaffolding if required and installation of gas solenoid valves where applicable.

ITEM TOTAL: £495.00

Sub Total	£3,202.00
VAT 20%	£640.40
Total	£3,842.40

We trust the above meets with your approval, should you require further info please give us a call, we can offer competitive lease purchase options for all capital equipment over £1000.00 + v a t please enquire for further details

Regards

Simon Mahony

Ebor Catering Systems Ltd

Mobile 07831 549855

Office 01706 291666

Halcyon AMH55 WSD

undercounter

DISHWASHER



Halcyon **AMH55 WSD** Features

- **1 year warranty**
- Three button bright LED display with soft touch controls and alarms menu
- Automatic continuous water softener, breaktank & drain pump as standard
- Accurate detergent and rinse aid peristaltic dosing pumps
- Dosing set up by fascia controls
- Easy clean parallel wash and rinse arm assembly
- Optional surface scrap tray filters



Supplied with one pegged (capable of holding 18 10" plates), one open rack (capable of holding 25 pint glasses) and cutlery insert.

Additional racks can be purchased at point of order:

Z972001 & **Z972003**

For additional information contact our Sales Team on

T: **0345 130 8070** E: sales@maidaid-halcyon.co.uk or visit www.maidaid.co.uk

Halcyon AMH55 WSD

undercounter DISHWASHER



Technical Data

Dimensions (W x D x H)	mm	580 x 610 x 810 + Feet	Wash tank element	kW	2.1
Feet height	mm	10-20	Boiler element	kW	6.0
Rack size	mm	500 x 500	Wash pump	kW	0.47
Maximum useable height	mm	340	Tank capacity	L	20
Door opening	mm	365	Noise emission	dB	≤ 55
Theoretical productivity	Racks/h	40	Packaging Specs		
Effective productivity	Racks/h	30*	Gross weight	Kg	70
			Cubic volume	m ³	0.45
			Dim. (W x D x H)	mm	670 x 690 x 980

*Allowing 30 seconds for reloading

Cycle times may vary depending on local conditions/services

Installation Diagram – All services must be within 1 meter

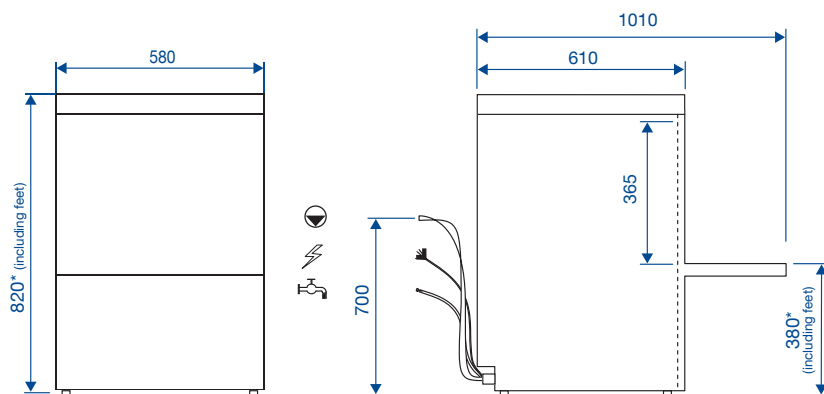

*Height-adjustable feet + 10mm

Power Supply

Installed power	AMP	KW
230V – 50Hz – 1N	13	2.6
	20	4.5
	30*	6.5
Optional 3 Phase config	Total load 6.5kW	
Fused	16 amp	

*Standard configuration

Pumped waste into upstand, maximum height 700mm

Power
Water supply 2 – 4 bar

Water Connection

Inlet water pressure	Bar	2 to 4
Flow rate L/Min	L/Min	6
Water inlet temp	°C	10 to 50
Water connection	BSP	¾"
Waste connection	Ø	Int 19/ext 24

Cycle Information

Number of standard cycles		2
Standard cycles times	Sec	90/180
Special cycle		Long
Self-cleaning cycle		Full self clean
Water consumption per cycle	L	2.5
Wash temperature	°C	60 – adjustable
Rinse temperature	°C	82 – adjustable

For additional information contact our Sales Team on

T: **0345 130 8070** E: **sales@maidaid-halcyon.co.uk** or visit **www.maidaid.co.uk**